

Instructions for #4017

Tech Line (816) 758-4504
 800-334-72240
 Fax (816) 758-4512

'33-'34 FORD 4-BAR REAREND MOUNTING KIT

For maximum strength, the bars in this kit are not adjustable. Therefore you must be very certain of the position of the rearend before welding any of the brackets in place. Have everything mocked-up in position and double check all measurements before tack welding any pieces together.

Stock rear fender hole

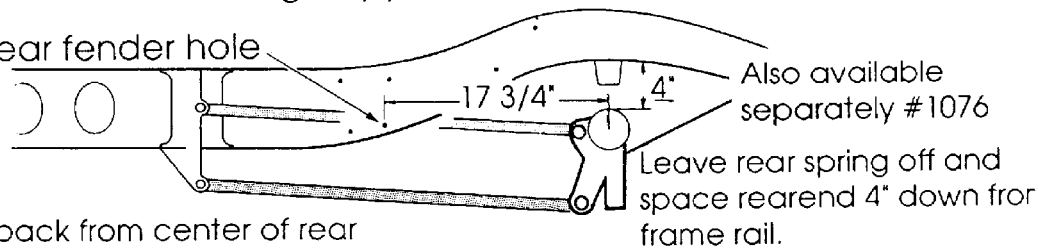

Center of rearend is 17 3/4" back from center of rear fender hole in side rail. Position rearend and work forward to locate brackets on x-member.

Have everything mocked-up in position before tack welding any pieces together.

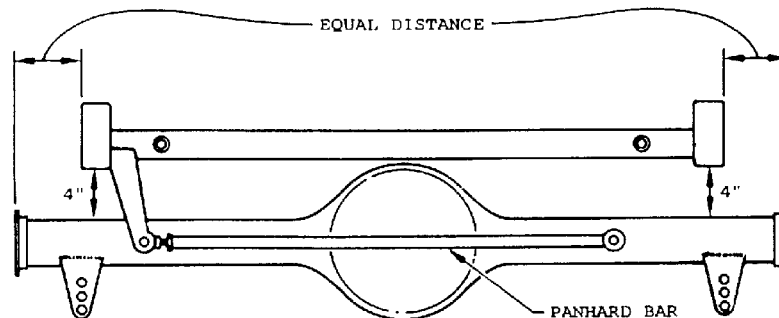
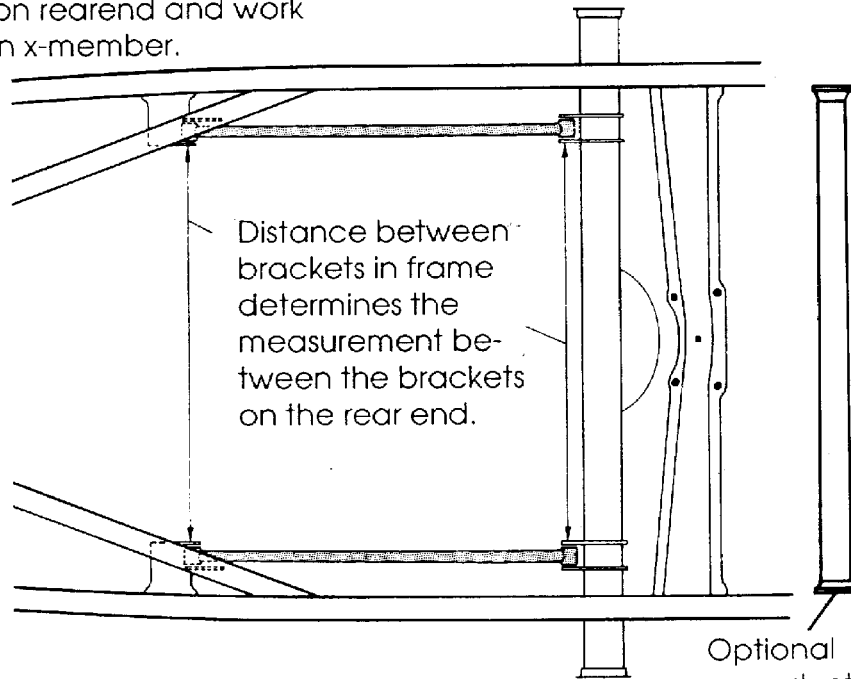

The lip of the frame channel can vary in width (x) from one side of the frame to the other. Trim edge of bracket plate (A) as needed to position inner edge (B) of bracket an equal distance (Z) in from the outside edge of the frame rail on both sides of the frame

