



# '35-'40 FORD

## COIL SHOCK REAR SUSPENSION KIT

For use with SPAX ELIMINATOR coil suspension shocks.

**IMPORTANT NOTE:** Remove the stock fuel tank from the car and put it in a safe place where sparks caused by the cutting torch cannot get to it. Removing the tank is also necessary to provide working room under the car.

**BODY OFF FRAME:** Drill out all the rivets (5 per side) that hold the stock crossmember into the frame. Removing the crossmember in one piece is nearly impossible, so cut the crossmember in pieces with a cutting torch to remove it.

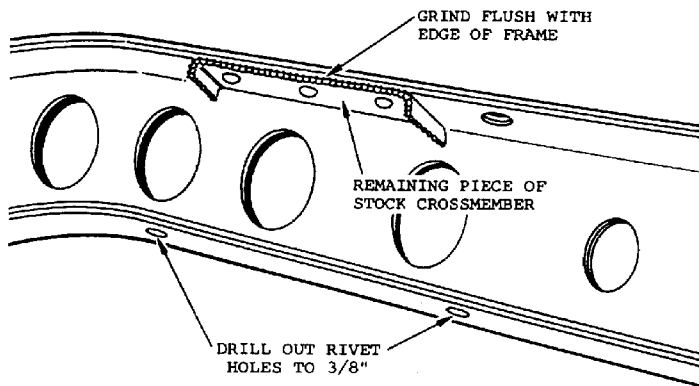

**BODY ON FRAME:** Drill out the rivets (2 per side) that hold the stock crossmember to the bottom flange of the frame. Because you cannot drill out the rivets on the top flange, use a cutting torch to cut away the crossmember around the area that is riveted to the top flange of the frame. Cut the crossmember in pieces to remove it. Grind the rough cut edge of the remaining riveted-on piece of crossmember flush with the edge of the top flange of the frame.

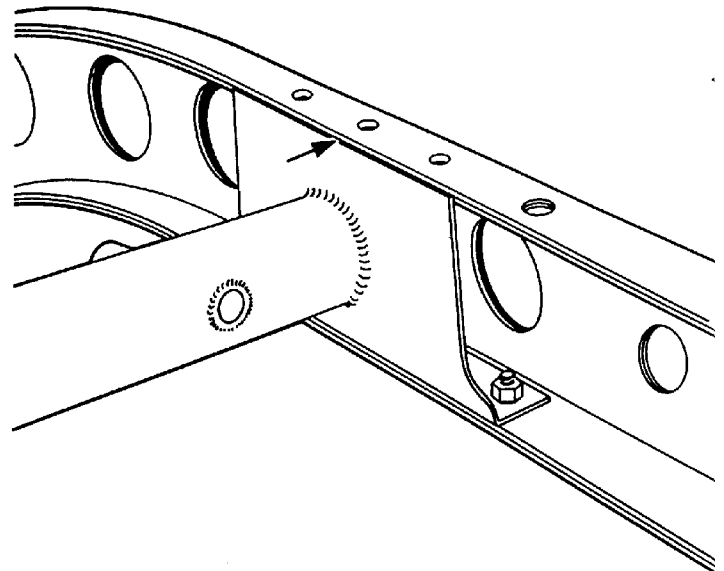
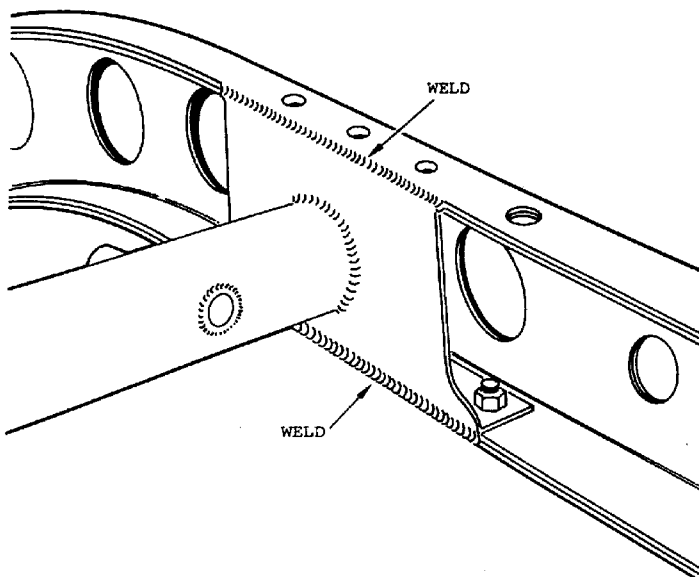

Bolt the new crossmember in place using 3/8" bolts through the stock rivet holes in the bottom flange of the frame. In some cases the end plate on the crossmember may need to be trimmed along the top edge (arrow) to expose the edge of the top flange of the frame for welding purposes. Mark the end plate as needed and remove crossmember to trim. Most '35 thru '39s should be OK as is, some '40s require trimming as much as 1/4".

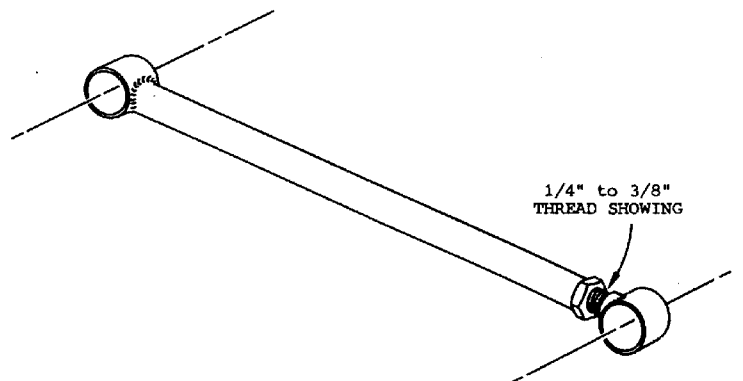

Assemble panhard bar and adjustable end with 1/4" to 3/8" of thread showing beyond the jam nut. Lay the assembled bar and end on a flat surface so bushing centerlines are parallel and tighten the jam nut.

When the crossmember is installed for the final time it must be welded to the top and bottom flanges of the frame for maximum strength. Bolted-in only is NOT strong enough!

*Pete & Jake's*

Pete & Jake's Hot Rod Parts • 401 Legend Lane  
 Peculiar, MO 64078 • Tech line 800-334-7240

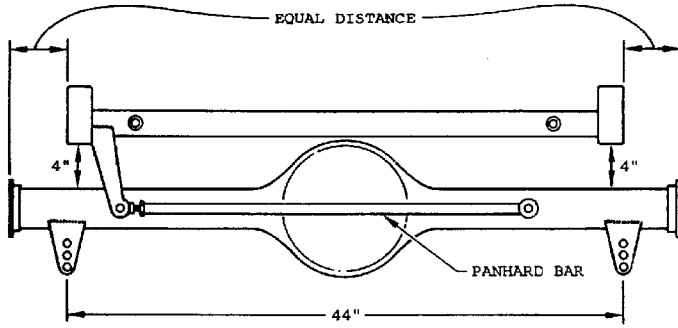

REAR VIEW

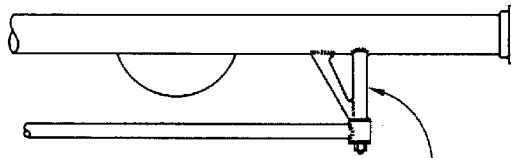

TOP VIEW

PANHARD BAR BRACKET WELDS  
 TO HOUSING WITH GUSSET  
 TOWARDS CENTER OF REAREND.

Position the rearend with equal distances on each side of the frame and 4" between the top of the housing and the bottom of the frame. Install the panhard bar into the bracket on the crossmember and position the bracket on the other end against the housing and weld in place.

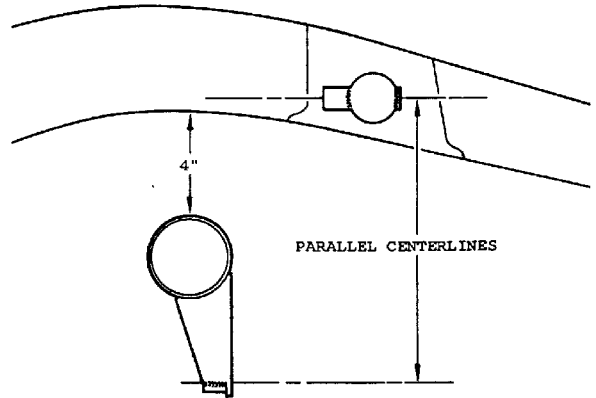

Mount the shock brackets on the housing with the centerlines of the tubes parallel to the tube through the crossmember. The housing should be 4" from the frame to approximate ride height.

